

**WORLD METEOROLOGICAL ORGANIZATION**

**COMMISSION FOR INSTRUMENTS AND METHODS OF OBSERVATION**

**Session  
of the  
International Organizing Committee for the  
WMO Intercomparison of GPS Radiosondes**

**Brasilia, Brazil**

**21 to 25 August 2000**

**FINAL REPORT**



# AGENDA

- 1. ORGANIZATION OF THE SESSION**
  - 1.1 Opening of the session
  - 1.2 Election of the chairman
  - 1.3 Working arrangements for the session
  - 1.4 Adoption of the agenda
- 2. INTRODUCTORY REMARKS**
- 3. OBJECTIVES OF THE GPS RADIOSONDE INTERCOMPARISON - PHASE I**
- 4. ORGANIZATIONAL PREPARATION OF THE INTERCOMPARISON**
  - 4.1 Agreement on test procedures
  - 4.2 Introduction of the test site and the available facilities
  - 4.3 Reference instruments / equipment to be used
  - 4.4 Radio-frequency issues
  - 4.5 Management structure and organizational issues
  - 4.6 Criteria for participation
  - 4.7 Identification of participants including provision of operators for running the test
  - 4.8 Date and duration of the intercomparison
- 5. MATERIAL ARRANGEMENTS FOR THE INTERCOMPARISON, INCLUDING LOGISTICS**
- 6. DATA COLLECTION, CHECKING AND PROCESSING PROCEDURES FOR THE INTERCOMPARISON**
- 7. DATA ANALYSIS AND PRESENTATION OF THE RESULTS**
- 8. ANNOUNCEMENT OF THE INTERCOMPARISON AND INVITATION FOR PARTICIPATION**
- 9. REQUIREMENTS FOR FURTHER TESTS, INCLUDING OTHER COMPARISON SITES IN THE TROPICS**
- 10. ANY OTHER BUSINESS**
- 11. CLOSURE OF THE SESSION**

\*\*\*\*\*

## GENERAL SUMMARY OF THE WORK OF THE SESSION

### 1. ORGANIZATION OF THE SESSION

#### 1.1 Opening of the session

The session of the *International Organizing Committee (IOC)* for the *WMO Intercomparison of GPS Radiosondes* was held on the kind invitation of the National Meteorological Service (Instituto Nacional De Meteorologia - INMET) of Brazil at its Headquarters building in Brasilia, from 21 to 25 August 2000. The lists of participants and their addresses are attached as [Appendix A](#) and [Appendix B](#).

The session was opened on Monday, 21 August 2000 at 10.00 a.m. by Mr A. Athayde, Director-General of INMET and Permanent Representative of Brazil with WMO. He welcomed the participants in Brasilia and noted INMET's pleasure in hosting the session. He then underlined the importance of getting reliable and accurate information especially for GPS radiosondes and emphasized the need for organizing a related intercomparison.

He informed the participants that INMET is operating a comprehensive network of upper-air stations based on GPS radiosondes and had obtained comprehensive experience in this field. Taking this into account and noting the intention for getting more information on the operational performance of this type of radiosondes, it was of great pleasure for INMET to offer to host such a comparison.

Finally, Mr Athayde was pleased to inform the session that INMET received the certification that it is working on the basis of ISO 9001, resulting from a long and intensive work within the whole Service for increasing the quality of its work. He offered any support for the meeting and wished every success for the session.

Mr K. Schulze welcomed as representative of the WMO Secretariat the participants in Brasilia and conveyed the best wishes and the gratitude from Professor G.O.P. Obasi, Secretary-General of WMO, to the participants. It was also of great pleasure for him to pass on the best regards of Dr Srivastava, president of the Commission for Instruments and Methods of Observation (CIMO) to the session. He expressed his gratitude to INMET for its invitation to organise the session of the IOC in Brasilia and for the excellent working conditions provided. He noted with appreciation the efforts of Member countries of WMO to enable their experts to participate and also that of manufacturers of GPS upper-air equipment for attendance of their representatives. He underlined the importance of carrying out intercomparisons for getting information on the performance characteristics under operational field conditions and the urgent need to carry out such a test for GPS radiosondes under tropical field conditions. He noted with great pleasure INMET being ready to host such an intercomparison. He finally wished the session every success in its work and an enjoyable stay in Brasilia.

#### 1.2 Election of the chairman

Dr Nash, chairman of the *CIMO Working Group on Ground-based Upper-air Observing Systems* was unanimously elected as chairman of the IOC.

#### 1.3 Working arrangements for the session

The session determined its working hours and the participants were informed on the local arrangements necessary for carrying out the session. English was selected as the working language.

#### 1.4 Adoption of the agenda

The Chairman introduced the Provisional Agenda and invited the participants to provide comments. The session agreed on a minor amendment and adopted the Agenda as basis for its work with the understanding that it could be amended during the session, if necessary. The final agenda can be found in front of this report.

## 2. INTRODUCTORY REMARKS

The chairman briefed the participants on the efforts previously undertaken by CIMO in getting information on the performance characteristics of upper-air observing systems under field conditions. He briefed the session on previous radiosonde WMO intercomparisons organized under the auspices of its *CIMO Working Group on Upper-air Observations*. The session was informed in some detail on the basic rules established by WMO for running such intercomparisons.

## 3. OBJECTIVES OF THE GPS RADIOSONDE INTERCOMPARISON - PHASE I

Based on the proposals made by the *Expert Meeting on Operational Issues for Radiosonde Applications in the Tropics and Sub-tropics* (Geneva, November 1999) and the *Working Group on Ground-based Upper-air Observing Systems* (New Delhi, December 1999), the session was briefed on the main purpose of the planned intercomparisons. The forthcoming test is intended to begin a new series of smaller WMO radiosonde intercomparisons, probably hosted at sites away from the main test centres in North America and Europe. This would lead to a difference in emphasis in the objectives compared to earlier WMO intercomparisons in order to keep the costs to hosts and participants within acceptable limits. Due to some concern on the quality of upper-air observations, the first tests were intended to be carried out under tropical conditions. One of the main objectives of the new series of tests is that they should be performed and the results be presented in a manner which helps manufacturers in improving their designs and to provide the required information on the performance characteristics of the participating systems to WMO Member countries.

At the forthcoming first field intercomparison of this new series information on the performance characteristics of the GPS-based windfinding system, such as on the quality of wind data, data availability, and reliability of the system, as well as on the relative humidity measurements of the participating sondes and systems were to be obtained.

It was agreed by the IOC that the WMO intercomparison to be held in Brazil should mainly be carried out as a scientific experiment for considering the specific needs in the tropics, i.e. it should not be considered as a general test of available systems which could generally be done in each other area of the world too. However, the manufacturers were concerned that all viable systems should be allowed to participate, because of the commercial consequences of non-participation given the long gap since the previous WMO test.

After a lengthy discussion, in which the attending representatives of the manufacturers concerned were involved and provided information on their goals of such a test, the IOC agreed on the following main objectives of the planned comparison carried out under tropical conditions in Brazil:

- a) To improve the accuracy of radiosonde measurements and the associated methods of observation.
- b) To test the accuracy and availability as well as the general performance of data obtained from the GPS wind measuring systems with at least 3 systems flown simultaneously up to heights of 25 km and to investigate reasons for malfunctions and failures. This may include a limited number of flights for specific tasks reaching greater heights.
- c) To evaluate the performance and usefulness of position measurements obtained from GPS radiosondes (location in the horizontal as well as vertical).
- d) To evaluate the performance of the most widely used radiosonde humidity sensors against the newly developed higher performance sensors.
- e) To investigate differences between day and night time measurements.
- f) To measure the differences between temperature and pressure sensors from widely used radiosondes against newly developed high performance sensors. This also includes investigations on their response time in the test environment.
- g) To investigate the practices used in the preparation of radiosondes for launch, operator in-flight interventions, as well as reporting and coding procedures on the operationally applied radiosonde products.

- h) To benefit the improvement of Brazil's operational upper-air practices from conclusions / recommendations derived from the intercomparison in which the routinely used radiosondes in the Brazil network and their operational practices were applied.
- i) To publish the final report of the intercomparison within the *WMO Instruments and Observing Methods Report series* (IOM) in due course after the test was finished. It was considered essential in this regard to prepare a concise summary report containing the main results for an immediate publication first, followed by a comprehensive full report with detailed information on the test in a reasonable time scale depending on the possibly needed clarification of detailed problems which may appear.

## 4. ORGANIZATIONAL PREPARATION OF THE INTERCOMPARISON

### 4.1 Agreement on test procedures

For facilitating the work of the IOC, the session was briefed on test procedures applied at previous WMO intercomparisons with the objective to consider their application in an adequate manner. Noting that recent experience obtained in GPS radiosonde tests carried out in mid-latitudes have shown that some systems may experience difficulties when flown with other radiosonde types, the IOC also considered whether multiple flights are not only suitable for testing operationally applied radiosonde types but also new GPS radiosonde designs. In this connection it was discussed that these could also be tested separately as individual flights if this is feasible at all or in a second comparison hosted at another location, once they have reached a mature operational state. Since this intercomparison was originally planned to be held in 2000 and is now scheduled for 2001 (see Section 4.8 below), it was found feasible to include all presently available and sufficiently tested GPS radiosondes in the forthcoming test, while some limitations in participation at multiple flights for newly developed designs were considered (see Section 4.5 below). Concise information on the performance of these new types of sondes can be found in [Appendix D](#).

The IOC noted that the greatest differences in radiosonde errors between the tropics and mid-latitudes occur in the troposphere and lower stratosphere. It was therefore agreed that the target heights required for the test flights could be to pressures lower than 30 to 20 hPa to be adequate for obtaining the requested results.

### 4.2 Introduction of the test site and the available facilities

The IOC agreed upon the proposal of Brazil to carry out the intercomparison at the Brazilian Air Force Satellite/Rocket Launch Centre (CLA) at Alcantara, State of São Luís do Maranhão, in the North of Brazil (*Latitude 2°18' South, longitude 44°22' West*). The design of this particular experiment needs to be based on the facilities and organizational conditions at the test site. Therefore the experts have given a comprehensive overview to the participants from the host country (see [Appendix C](#)). It also included information on the expected temperature, relative humidity, precipitation at the surface and upper-air profiles during the proposed test period at the test site (see [Appendix E](#)).

### 4.3 Reference instruments / equipment to be used

The IOC discussed in depth the application of instruments, equipment, and procedures to be used as comparison references. In noting the main objective of the intercomparison, namely the determination of the performance characteristics of the upper-air systems involved and especially of the accuracy of the wind data, the application of a tracking radar as reference equipment was considered to be beneficial in addition to the approach in using at least 3 different types of GPS radiosondes.

Related to the application of reference equipment for humidity measurements, the IOC agreed that the "Snow White" Chilled Mirror Hygrometer of Meteolabor AG (Switzerland) should, as far as possible, be used as an independent high quality comparison reference instrument attached as a sensor to radiosondes. The "Snow White" sensor already proved to perform accurately in recent national radiosonde tests. Since experience with the application of this sensor on the Sippican Mark II radiosonde have already been obtained, it was agreed to apply this combination at specific flights with the Sippican radiosonde, as to be determined later in the detailed flight

schedule. The "Snow White" system needs to be used together with measurements from the Vaisala RS90 radiosonde (used to determine when the water surface on the chilled mirror freezes, or if the sensor cooling is insufficient in the upper troposphere and lower stratosphere) to provide a best reference.

The IOC also considered the need for using a reference for temperature measurements. In this connection, the 3-thermistor combination was taken into account, which proved its usefulness in daytime measurements as a possible reference during previous tests. Efforts would be made to see if a limited number of 3-thermistor radiosondes could be provided for some of the test flights. For general presentation purposes of the upper-air temperature, the sensors of Sippican Mark II and Vaisala RS80 will be used as relative reference also linking back to earlier WMO intercomparisons. For specific interpretation of the results, the project leader will choose the most reasonable reference.

For the application of any reference instruments it has to be considered that their use should be reduced to the minimum needed due to the additional costs required. This is especially essential for the tracking radar (possibly one-each ascent at day- and night-time only) since funding for a magnetron might be required. In any case, an estimate of the expected costs of the possibly required magnetron has to be provided by the host country as soon as possible. The chairman of the IOC will consider a solution for possible funding in close collaboration with participants and the PL representing the host country.

It was agreed in this context that the "Snow White" dew point mirror sensor should be used as a reference instrument for humidity measurements for a maximum of 20 flights only, depending on the availability of its funding. Financial support was promised by its manufacturer, METEOLABOR AG, Switzerland, as well as possibly by the Met Office (UK).

In addition to these required in-flight references, equipment must be available for accurately observing the basic meteorological variables at surface level, such as temperature, humidity, pressure, wind, present weather, and, if at all possible, height of clouds. Related to the latter, the representative of Vaisala will consider whether it might be possible to provide free of charge a ceilometer for the test period. In this context, the IOC considered that it would be highly appreciated if a high quality sensor for obtaining reliable relative humidity surface observations could be made available, such as the high precision dew point mirror, i.e. "Thygan" which is produced by METEOLABOR AG, Switzerland. This equipment already proved its usefulness at a previous radiosonde comparison. The representative of METEOLABOR AG was kindly invited to consider providing such an instrument for the test period, if possible free of charge.

Since the performance of radiosonde pressure sensors during the flights cannot be assumed to be similar to previous tests, the geopotential heights derived from pressure sensors will be compared to the geopotential height data obtained from GPS and from the tracking radar, as far as these measurements are available.

#### **4.4 Radio-frequency issues**

The IOC drew its attention to radio-frequency issues related to the participating radiosonde systems. It was considered that radiosondes working within the 403 MHz and possibly also within the 1680 MHz radio-frequency band could be flown in the intercomparison. According to the information of the host, there will be no restriction in this regard, i.e. in getting the legal permission for operation. Furthermore, the Project Leader (PL) will be informed on the frequencies intended to be used by the potential participants as soon as possible so that further clarification can be achieved, if required.

Specific attention was directed at the session to agree on measures that will prevent any radio-frequency interference between the various types of sondes during the test, as well as with systems operated by the host for various purposes at the comparison site (such as Radars, telecommunication, etc.). Regarding these matters, information was provided by the operator of the test site that there are no transmitters (especially Radars) in use, which would jeopardize the radiosonde operation. Regarding the considered participation of the InterMet radiosonde operated within the 1680 MHz band, which could be a source of interference, the manufacturer will undertake tests to explore and prevent a negative impact. If this cannot be realised, participation will be realised with a 403 MHz radiosonde only.

#### 4.5 Management structure and organizational issues

The IOC discussed and agreed upon the responsibilities of the host country as well as on that of the participating industry for preparation and running the forthcoming intercomparison.

According to the guidelines established for WMO intercomparisons (see "CIMO Guide", WMO-No. 8), a Project Leader (PL) has to be nominated who is responsible for preparation and running the test as well as for the evaluation of data and preparation of the Final Report. The chairman and the members of the IOC will assist the PL, as far as requested and possible. Specific responsibilities should also be allocated by the Chairman of the IOC to the experts serving in it.

Dr R. da Silveira, INMET, was nominated PL by the host country. Based on this report and further information received from the potential participants as well from the operator of the comparison site, he will develop the project structure and the detailed schedule for the intercomparison. These documents have to be sent to the chairman of the IOC for confirmation and following this to the potential participants.

As successfully applied at previous WMO intercomparisons, it was agreed that the nomination of a Site Manager (SM) would be useful. He will support the PL and is, among others, responsible for several detailed organizational matters especially related to the test site (reception of equipment, preparation of the site, carrying out the test practically, etc.). The IOC recommended that this nomination should be done as soon as possible to widely facilitate the preparatory work of the PL.

Similarly as valid for the SM, the nomination of a Data Manager (DM) would also significantly facilitate the work of the PL and should be considered. The nomination of the SM as well as of the DM should be done by the host country. The PL should inform the IOC as well as the potential participants on this nomination.

The vendors expected to participate in the test shall be fully responsible for the transportation of all submitted equipment, all import and export arrangements, and any costs arising from these. Correct import/export procedures shall be followed to ensure that no delays are attributable to this process. Participants shall generally install and remove any equipment under the supervision of the PL assisted by the SM, unless the host country has agreed to do this. Each participant shall provide all necessary accessories, mounting hardware, signal and power cables and connectors (compatible with the standards of the host country), spare parts, and consumables for its equipment. A participant requiring a special or non-standard power supply shall provide his own converter or adapter. Participants shall provide all detailed instructions and manuals needed for installation, operation, calibration, and routine maintenance, if applicable. (see also relevant information as provided in [Appendix C](#))

Related to specific organizational matters in preparation of and at the intercomparison, the following requirements and guidelines should be considered (see also *Plan of Main Measures ...* as contained in [Appendix G](#)):

- a) A method of starting should be agreed upon with the participants. Time synchronisation for the launch has to be done precisely, best with a trigger pulse available at all ground stations and also at the tracking radar. (see a proposal for implementation as contained in [Appendix F](#)) If this is not feasible, an adjustment could possibly be done afterwards on the data sets as a provisional solution. In any case, the participants are invited to retain the record of the GPS time as a function of the time into flight recorded by their ground systems.
- b) Detailed and representative information on all surface observations at the Alcantara test site, such as temperature, humidity, wind, pressure, precipitation, cloud height (preferably with a ceilometer), and present weather, should be provided. The atmospheric pressure should preferably be measured directly at the release point.
- c) The potential participants should take into account a distance from their antennae to the ground facility of up to 30 m and have the cable lengths to support the distance.
- d) A precise determination of the location of the GPS ground antennae is required.

- e) *A list of activities should be established by the PL, which reflects the whole process of preparatory work for the intercomparison.*
- f) In preparation of and carrying out the test, it could be considered from experience obtained at previous trials that a maximum of 4 GPS systems can be flown together without causing interference.
- g) It is recommended to use a rig for fixing the radiosondes underneath of the balloon. The construction of the rig needs to be determined. Messrs J. Nash and F. Schmidlin will provide a proposal for a possible construction to facilitate the work of the PL in due course.
- h) Individual tests of the participating systems should be made at the comparison site immediately prior to the intercomparison to guarantee the proper individual operation of the systems to be compared and to prevent problems during common flights caused by interference between some radiosondes.
- i) It was considered that 40 ascents are sufficient for getting reliable test results. The required number of radiosondes (at least 50) will be provided by the participants.
- j) Related to the balloons, it was agreed that approx. 30 balloons of 1200g size and 20 2000g balloons are required for covering all needs. The participating vendors will share the costs accordingly. (The 1200g balloon may guarantee a height >25 km with 4 sondes attached which is sufficient for this test.)
- k) Parachutes should be applied at all ascents during the test. Mr C. Bower (NWS/USA) will consider provision of about 100 so that 2 could be applied at each launch.
- l) Radar targets are needed and are intended to be provided by INMET.
- j) Although no restrictions are expected, the PL has to consider air-traffic regulations for the ascents since larger balloons are used than for routine observations.
- k) Participants may consider that there could be problems with some systems in preparation of the battery prior to the test (i.e. it may take longer time and could delay the launch) (see 4.5 below). The low temperatures in the tropics (-90°C) may also create some problems compared with other areas.
- l) The flight time of ≈80 min for the 1200g balloons or ≈120 min for the 2000g balloons should be taken into account especially regarding the battery life time. In this regard it has also to be noted that the temperature at the tropopause may go down to -90°C.
- m) Participating systems have to be clearly documented, including the software version applied, so that the measurements are traceable.
- n) Launching times proposed are: Local time: 21:00, 3:00, 9:00, 15:00 h (UTC: -3h)
- o) The IOC agreed upon the following preliminary launch schedule (local time):

<b>21:00</b>	<b>3:00</b>	<b>9:00</b>	<b>15:00</b>	<b>Weight (with GPS)</b>
Vaisala RS80 <sup>1</sup>	Vaisala RS80	Vaisala RS80	Vaisala RS80	≈250g
Sippican MKII & Snow White	Sippican MKII	Sippican MKII	Sippican MKII & Snow White	≈350g ≈350g
Dr Graw DFM	InterMet/Geolink GL98 IMS	Dr Graw DFM	InterMet/Geolink 1680 MHz <sup>2</sup> 403MHz (300mW)	Graw: ≈250g InterMet: ≈ 400g Geolink: ≈400g
Vaisala RS90	-	-	Vaisala RS90	≈250g
2,000g balloon	1,200g balloon	1,200g balloon	2,000g balloon	-

- p) Due to significant time needed for customs clearance, the equipment as well as the consumables needed for the intercomparison have to arrive in Brazil at least 2 months in advance prior to the intercomparison.

<sup>1</sup> Equipped with A-Humicap

<sup>2</sup> 1680 MHz is preferred by InterMet however there is a concern that interferences cannot be prevented with the 403 MHz. Therefore InterMet will make some confidence test prior to a decision which frequency should be used.

- q) Detailed information on the transport of the equipment to the comparison site (address, final shipping, etc.) as well as travel arrangements for participants to Alcantara will be provided to the potential participants in due course prior to the test by the PL. (see also [Appendix C](#)) Clearance for participants for going to Alcantara is needed at least 4 weeks in advance. A specific form will be made available by the PL.
- r) Power supply at the comparison site: 110 and 220V both 60 Hz. An internal stable power generator can be put into operation at Alcantara, if required. Most of the sockets are applicable for a 2-pin-plug compatible with the two different plug / socket systems as widely used in Europe and in the USA respectively. It has, however, to be noted in this context that there is only a limited availability of sockets with a third pin guaranteeing the "ground connection" with a socket design which was unknown at the session. (see also [Appendix C](#)) In any case, users have to be prepared to use suitable adapters for operation as well as present their power supply requirements to the PL in due course.
- s) Hotel accommodation is available at Alcantara with a distance of about 7 km from the comparison site. (see also [Appendix C](#))
- t) Individual group medical insurance should be made through Brazil Airforce. Examination will be done at Alcantara for a reasonable price if the participants are willing and their names are known in advance. (see also [Appendix C](#))
- u) The tracking radar is available at a distance of 500m from the launching. The radar cannot start to track the balloon immediately after launch due to the missing visible contact. This slightly delayed tracking seems to be preferable to widely prevent RF interferences during the launch procedure. During night-time, an illumination on the balloon is needed so that the radar can find the target. The PL will take care of it.
- v) Internet connection for E-mail is available via telephone Modem. Participants will have access to telephone and Fax.
- w) The balloon filling with Hydrogen can be done by permitted experts only. The safety rules for Alcantara have to be fulfilled. Rules have to be set up to prevent interferences and negative impact with the routine operation at the Alcantara upper-air station. Details will be considered in due course by the PL.
- x) An illumination of the starting area at night time is needed.
- y) The liaison with the Alcantara Brazil Air Force staff will be done through the PL only, i.e. **not** directly by any participant in preparation of the intercomparison. A plan of measures for the preparation of the test will be established by the PL based on the requirements set up by the Alcantara staff.
- z) The flight data generated at the intercomparison are intended to be sent daily to the forecast centres in Brazil, USA, and UK for getting information on the quality of the observations made. It is proposed to use the Alcantara WMO station number for this purpose. Clarification has to be made by the PL whether this is possible from the point of view of the host.

#### 4.6 Criteria for participation

The IOC generally considered the rules for participation at the intercomparison as well as the duties of participants. The IOC recommendation which is reflected below is mainly based on the general rules established by WMO for carrying out these kinds of trials, as partly reiterated below.

The IOC confirmed that according to the general approach for organizing WMO intercomparisons, routinely used ground equipment and radiosonde types should be confirmed for participation. However widely tested systems, which demonstrated a capability to meet stated WMO user requirements for measurement accuracy on a regular basis, supported by test data from a recognised independent site, might be considered for inclusion in the test if the technical and organizational conditions permit. If this cannot be proved, participation in the WMO Radiosonde Comparison Programme will have to wait until another phase of the test. Following this, considerations have also been made by the IOC to include in the test, as far as feasible, new

designs of radiosondes / sensors if they have already reached a certain stage of reliability (see also item 4.1 above).

The IOC considered in its considerations for selection of suitable participants at the intercomparison the resources available by the host country and the conditions at the comparison site to guarantee a successful running of the test. It was reiterated in this regard that additional tests are planned to be held in due course (see also item 8. below).

In further discussing this matter of highest importance for preparing the intercomparison, it was stated that adequate testing of GPS radiosondes will require upper-air ground systems that can record and provide raw data files<sup>3</sup>, especially in order to identify the cause of failures or data dropouts in GPS winds. Furthermore, it was considered important especially for GPS windfinding to clearly define the version (or versions) of data processing software to be used within the systems included in the forthcoming test.<sup>4</sup>

Resulting from this discussion it was agreed that the following vendors could attend with radiosondes as defined in the schedule (see also Section 4.5 above):

- Vaisala (Finland)
- Sippican (USA)
- Dr Graw (Germany) (at a limited number of flights)
- InterMet (USA) and Geolink (France) conjointly (at a limited number of flights)
- Meteolabor AG (Switzerland) for provision of "Snow White" dew point sensors

The representatives of all manufacturers concerned agree with this decision.

#### **4.7 Identification of participants including provision of operators for running the test**

It has been suggested by the IOC that staff for running the intercomparison, i.e. operating the participating radiosonde systems, should as far as possible be provided by the host country with a limited number of advisers from the participating manufacturers, so that a realistic picture of radiosonde performance can be obtained at least for the systems routinely operated in Brazil. It should be noted that this approach has not been attempted in previous tests.

In addition to the local staff available assisting in the operation of at least the routinely applied system(s) in Brazil, it was agreed that the following number of staff might be provided by the participating vendors:

- Vaisala: 4 operators
- Sippican: 2 or 3 operators
- Geolink: 3 or 4 operators
- InterMet: 3 operators
- Dr. Graw 2 or 3 operators

The vendors have to provide detailed information on the number of experts to the PL in due course prior to the test.

#### **4.8 Date and duration of the intercomparison**

The discussion of the IOC related to the date and duration of the intercomparison was based on the results of the considerations above as well as on some aspects related to the material preparations of the test (see also item 5. below). Since the originally considered period from 4 to 14 December 2000 was not feasible due to organizational constraints and especially because of the rules for importing equipment, the period proposed by the host country for the intercomparison in Alcantara is **from 21 May to 10 June 2001**. Therefore, the total duration is 21 days. The IOC agreed on this proposal. It noted that specific preparation time of the participating teams of 2 days prior to the official test for installation and individual testing is highly recommended.

<sup>3</sup> Format and contents to be defined by the PL at a later stage during the preparation of the test.

<sup>4</sup> To be defined by the PL at a later stage during the preparation of the test.

## 5. MATERIAL ARRANGEMENTS FOR THE INTERCOMPARISON, INCLUDING LOGISTICS

All material arrangements for preparation of, and running the intercomparison as well as related to the evaluation and presentation of the results have been considered by the IOC and brought to a decision. This includes the equipment (such as ground-equipment, radiosondes, balloons, hydrogen, etc.), the import and export arrangements, experts participation (visa formalities, permission for entering the test site, etc.). The IOC agreed upon the following material arrangements and logistic measures while some issues, which are already reflected in Section 4.5 above, are intentionally reiterated here again (see also [Appendix G](#)):

- a) It has to be considered that realistically two months are needed for getting the instrumentation shipped from vendors to the comparison site in Brazil.
- b) All participating vendors will provide radiosondes required for the test free of charge.
- c) The provision of balloons cannot be resolved by Brazil therefore it was agreed that vendors would share the costs. It was agreed that all related arrangements will be coordinated by Sippican.
- d) The "Snow White" humidity sensor should be applied as reference during night flights only. (20 sensors would preferably be required, depending on day/night time). The Met Office (UK) and METEOLABOR, Switzerland, may consider provision of support for it. The "Snow White" sensor should be flown with Sippican Mark II radiosonde where experience already exists. However, UK will still do additional tests. The RS90 radiosonde and the MARK II with the "Snow White" sensor attached should always be flown on the same ascents.
- e) A Tracking Radar is intended to be made available for some flights. The PL in close collaboration with the SM will consider its mode of operation (such as working in shifts and during the weekends).
- f) Brazil is requested to equip the operationally used Vaisala DIGICORA II with "Metgraph software" for also getting access to the raw data sets which are useful for data evaluation. The staff operating DIGICORA II as well as the Sippican system (latter has a similar software already implemented) should sufficiently be trained prior to the test to correctly apply this feature adequately. The UK will consider the provision of an additional DIGICORA III system with a display which is operating with this METGRAPH software and gives access to all individual data.
- g) The DIGICORA II (operationally used at Alcantara) updated with METEGRAPH software will be used for the intercomparison. Backup systems will be considered to be made available by INMET for the Vaisala- and by Airforce for Sippican-System from other sites.
- h) Carrying out the ground check for all participating radiosondes prior to launch is essential while specific attention should be given to humidity measurements. For this purpose, METEOLABOR has been invited to provide for reference purposes (humidity and temperature) the THYGAN thermo-hygrometer.
- i) If unexpected serious problem with one or more upper-air systems (including radiosondes) occur at the intercomparison, it is up to the PL to make the necessary decision(s) on how to proceed best resulting from discussion with participants concerned and, preferably, in consultation with the IOC via its chairman.
- j) It would be preferable to have a ceilometer available at the comparison site (Vaisala will consider providing one).
- k) It should be considered whether unwinders (USA: dereelers) can be made available at launch for the participating sondes.
- l) Specific issues related to the power supply, grounding, plugs and sockets, etc. will be distributed in detail by the PL to the vendors.

- m) It was considered essential to note that the import of equipment is not an easy undertaking, i.e. equipment should arrive in Brazil by February/March 2001. The transport of equipment to Alcantara is not an easy logistic undertaking.
- n) The PL will provide the shipping address for the equipment to the participants.

More detailed information on the major measures and activities can be found in the summary table as contained in [Appendix G](#).

## **6. DATA COLLECTION, CHECKING AND PROCESSING PROCEDURES FOR THE INTERCOMPARISON**

The requirements for the data acquisition and processing facilities have been discussed. Taking into account the available facilities at the comparison site, procedures on how to proceed with the quality check and data processing were developed. (see [Appendix H](#)) Suitable algorithms for the data processing were discussed, such as the already for this purpose the well proven Evaluation Software developed by Kurnosenko (Russian Federation) and Oakley (UK).

Some of the most important activities are summarized below while a plan containing detailed measures needs to be developed by the PL in close collaboration with the DM.

- a) The data should be submitted to the data collection expert at the site at least within one hour after the test flight termination.
- b) The data should be delivered in an agreed format, preferably sampled at 2 s intervals, but possibly at 10s. Details need to be defined through individual contacts between the vendors concerned and the PL and, if needed, in consultation with the chairman of the IOC. Test files should be sent after delivering the software by the vendors to the PL and DM, Drs R. da Silveira and G. Fisch, respectively.
- c) Initial evaluation of Temperatures on data quality should be done with the Kurnosenko/Oakley software package. (The latest version will be provided by J. Nash to the PL and the DM).
- d) After evaluation of the data only the PL is allowed to amend data if there are good reasons for doing so.
- e) The Data processing plan has to be established in considering the following main issues:
  - Examining the basic data coming out of the system (i.e. with real time checking)
  - The raw (log) files can be used for re-run of the TEMP code by the vendor
  - Data for standard Temp message should be provided to the DM

## **7. DATA ANALYSIS AND PRESENTATION OF THE RESULTS**

The IOC discussed matters related to the analysis of the data. It further agreed to present the results of the intercomparison as a publication within the WMO Instrument and Observing Methods Report (IOM) series either as printed copy and/or as CD ROM. The Final Report of the intercomparison should also be made accessible through WMO/CIMO's Web-site.

**In presenting the Statistical results, the following ideas should be taken into account:**

### Wind:

The comparisons should be performed for orthogonal (u, v) components and also for wind speed and wind direction. The results should be compared to the average of the 2 most reliable systems available. Comparisons with the data from the tracking radar could also be taken into account.

### Humidity U:

Systematic differences between systems must be presented as a function of U, and should also be considered as a function of temperature (some sensors may not function at temperatures lower than  $-40$  or  $-50^{\circ}\text{C}$ ). Differences in performance between day and night can also be expected.

If there is significant rain during a flight, the relative humidity sensor performance may also be very different from dry conditions.

The “*Snow White*” measurements combined with the new RS90 humidity sensor should be recognised as working reliably to lower temperatures than some of the older radiosonde sensors.

#### Temperature T, Pressure P, and Height $\Phi$ :

Differences need to be computed in pressure/height bands as for previous WMO comparisons for each flight time.

The individual test data will be provided by the DM together with the reference data to the participants.

The IOC agreed that it will be highly beneficial to prepare a concise Summary Report containing the most important comparison results first. The target will be to have it ready for publication 6 months after finalizing the test. The comprehensive Final Report should be published not later than 18 months after the test. Both are published within the WMO IOM series.

### **8. ANNOUNCEMENT OF THE INTERCOMPARISON AND INVITATION FOR PARTICIPATION**

The IOC discussed matters related to the invitation of Member countries for participation at the test by WMO represented by the interested industry related to the countries concerned. A principal agreement was achieved on potential participation of the following vendors:

- Vaisala (Finland),
- Geolink (France),
- Dr. Graw (Germany),
- InterMet (USA),
- Sippican (USA), and
- METEOLABOR AG (Switzerland) for provision of support with reference instruments.

The IOC invited the Secretariat to prepare and distribute letters of invitation to the PRs of the Member countries concerned. Copies of the letter should be sent to the PR of Brazil, to the presidents of WMO Regional Associations, and to the vendors concerned for information.

Brazil also intends to inform the Members of RA III on this undertaking.

### **9. REQUIREMENTS FOR FURTHER TESTS, INCLUDING OTHER COMPARISON SITES IN THE TROPICS**

The IOC considered that the forthcoming intercomparison which is designed to cover the specific conditions within the tropics for GPS radiosondes but it will not yet fully meet the needs for recognition of all newly developed radiosondes although they have proved sufficiently reliable. Therefore, a further test in mid-latitudes might be considered for this purpose. Already established test sites could be considered for carrying out this test in due course. This might still be of high importance for WMO Members and vendors.

In summarizing the main results of the related discussions, the reasons for having a series of comparisons in continuing the forthcoming in Brazil are the following:

- The forthcoming test of humidity sensors carried out in the tropics don't cover all upper-air climatic and seasonal conditions for humidity observations, therefore to more generally cover the conditions which appears in some other regions (such as RA I and II) the series has to be continued with smaller tests.
- India and China have some significant problems with the quality of observations obtained with their nationally produced sondes. This may result in specific tests to be organized there.

Although the forthcoming test in Brazil will give all potential vendors the chance to initially attend the intercomparison, it is, however, expected that deficiencies will appear in the performance of some sondes, which may also lead to further considerations.

In any case, it was agreed upon, that further tests should be considered to be carried out not more often than in 2-yearly intervals. Depending on the outcome of the forthcoming intercomparison in Brazil, the IOC has to deliberate in due course afterwards where the next test should preferably be held. This considerations should also include whether there is a need for a further tropical test (such as in Africa) and/or trial within mid-latitudes (such as in Europe or North America).

Dr Nash, in his capacity as the chairmen of the *CIMO Working Group on Ground-based Upper-air Observing Systems* and of the IOC, which was established for the forthcoming and the following test, also in using his experience as PL of previous tests, should in consultation with the members of the IOC develop proposals for follow-up tests. Especially the reduction of expenditures for preparation of and running these tests should be taken into account to make it feasible for the host country as well as for potential participants.

## **10. ANY OTHER BUSINESS**

The participants highly appreciated the guided tour through the headquarters of INMET personally conducted by Mr Athayde, the Director of the Service. This tour demonstrated the capabilities and high performance of INMET for the benefit of Brazil as well as related to the service provided to the other Members of South America.

The session also briefly considered issues related to the still not yet published *Report of the WMO Radiosonde Humidity Sensor Intercomparison*. As a matter of urgency, it invited Dr Nash, the PL of this previous test, to have the Report finalized and submitted for publication to WMO as soon as possible so that it may be published in 2000.

## **11. CLOSURE OF THE SESSION**

All participants were unanimous in their gratitude to INMET for the excellent hospitality provided and for making arrangements to ensure the meeting was a success.

Dr Nash thanked the participants for their active work and their valuable contributions provided at the session. He highly appreciated the interest shown in the matter of concern by all experts and especially the interest shown and assistance given by the experts from Brazil who attended the meeting.

Mr Schulze thanked all experts for their lively discussions and their dedicated work. On behalf of the participants, he thanked Dr Nash for his excellent chairmanship. He underlined that it was very important that representatives of all major GPS-radiosonde producers attended the session as observers which significantly contributed to the success of the session and facilitated the preparation of the planned test. He wished the participants every success in their work and a safe trip home.

The session of the IOC was closed on Friday, 25 August 2000, at 1.00 p.m.

\*\*\*\*\*

## APPENDIX A

### LIST OF ATTENDANCE

Name	From	Function
------	------	----------

---

#### ***Members of the IOC***

1	J. Nash	UK	Chairman
2	R. da Silveira	Brazil	
3	C.A. Bower	USA	
4	F. Schmidlin	USA (Invited expert)	
5	J.-L. Gaumet	France	

#### ***Representatives of manufacturers as observers<sup>5</sup>***

6	T.A. Curran	Sippican (VIZ) USA	
7	J. Caminha Campos	Sippican (VIZ) USA (Advisor - Brazil Representative)	
8	J.A. Parini	InterMet Systems, USA	
9	V. Antikainen	Vaisala, Finland	
10	G. Feitosa	Vaisala, USA (Advisor - Brazil Representative)	
11	R. Pepin	Geolink, France	
12	J. Thieme	Dr. Graw, Germany	
13	P.W. Ruppert	METEOLABOR, Switzerland	

#### ***Observers/advisors from Brazil<sup>6</sup>***

14	A. Dall'Antonia	INMET	
15	J.E. Rodrigues	INMET	
16	F. Manhães	INMET	
17	Ten Cel. Zanutto	CINDACTA 1	
18	L.A. de Oliveira	Centro Hydrografia DA	
19	Ten Cel. C. Edison Gomes	DEPV	
20	G. Fisch	Centro Técnico Aeroespacial (CTA)	
21	L. A. Toledo Machado	Centro Técnico Aeroespacial (CTA)	
22	Mj. C. Moura	Satellite/Rocket Launch Centre (CLA-FAB)	
23	Cel.-Av. J. Lobato Campos	Satellite/Rocket Launch Centre (CLA-FAB)	

#### ***WMO Secretariat***

24	K. Schulze	WMO, WWW-B	
----	------------	------------	--

\*\*\*\*\*

---

<sup>5</sup> Part-time participation

<sup>6</sup> Part-time participation

## APPENDIX B

### LIST OF ADDRESSES

#### Members of the International Organizing Committee

**Dr John Nash**

Met Office, RS(5)  
Beaufort Park, Easthampstead  
WOKINGHAM  
GB-Berkshire, RG40 3DN  
United Kingdom  
Tel: (+44 1344) 85-5649  
Fax: (+44 1344) 85 5897  
E-mail: jnash@meto.gov.uk

**Mr Carl A. Bower, Jr.**

NOAA, National Weather Service W/OSO14  
- Observing Systems Branch -  
1325 East West Highway  
SSMC 2, Room 4112  
SILVER SPRING, MD 20910-3283  
USA  
Tel: (+1 301) 713 0722 (ext. 145)  
Fax: (+1 301) 713 0959  
E-mail: carl.bower@noaa.gov

**Mr Francis J. Schmidlin**

Code 972  
NASA, GSFC  
Wallops Flight Facility  
WALLOPS ISLAND, VA 23337  
USA  
Tel: (+1 757) 824-1618  
Fax: (+1 757) 824 1036  
E-mail: fjs@osb1.wff.nasa.gov

**Dr Reinaldo B. da Silveira**

Instituto Nacional de Meteorologia (INMET)  
Eixo Monumental - Via S1  
70610-400 BRASILIA DF  
Brazil  
Tel: (+55 61) 343 1779 or 344 9955 (ext. 283)  
Fax: (+55 61) 343 1487  
E-mail: rsilve@inmet.gov.br

**Dr Jean-Louis Gaumet**

METEO-France  
Direction des Systemes d' Observation - DOA  
BP 202  
F-78195 Trappes  
France  
Tel: (+33) 1 3013 6470  
Fax: (+33) 1 3013 6060  
E-mail: jean-louis.gaumet@meteo.fr

#### Representatives of manufacturers

**Mr Veijo Antikainen**

VAISALA Oyj  
P.O. Box 26  
Vanha Nurmijärventie 21  
Vantaa  
FIN-00421 Helsinki  
Finland  
Tel: (+358 9) 8949-1 (or -260 direct)  
Fax: (+358 9) 8949-338  
E-mail: veijo.antikainen@vaisala.com

**Mr Jürgen Thieme**

Dr. Graw Messgeräte GmbH & Co  
Muggenhofer Str. 95  
D-90249 Nürnberg  
Germany  
Tel: (+49 911) 3201-100 (or -107 direct)  
Fax: (+49 911) 3201-157 (or -151)  
E-mail: thieme@graw.de

**Mr Joseph A. Parini**

InterMet  
6095 28th Street SE  
Grand Rapids, MI 49546  
USA  
Tel: (+1 616) 285 7810  
Fax: (+1 616) 957 1280  
E-mail: jparini@intermetsystems.com

**Mr Thomas A. Curran**

SIPPICAN, INC  
Meteorological Systems Group  
Sea-Air Systems Division  
525 Plymouth Rd, Suite 307  
Plymouth Meeting, PA 19462  
USA  
Tel: (+1 610) 397-0183 (ext: 1)  
Fax: (+1 610) 397 8647  
E-mail: tom.curran@sippican.com

**Mr Rémy Pepin**

GEOLINK S.A.  
Quartier La Chaume - Pont del'etoile  
F-13360 Roque vaire  
France  
Tel: (+33) 4 4232 9974  
Fax: (+33) 4 4232 9495  
E-mail: rpepin@alhena-groupe.com

**Mr Paul W. Ruppert**

Meteolabor AG  
Hofstr. 92  
CH-8620 Wetzikon  
Switzerland  
Tel: (+41 1) 934 4040  
Fax: (+41 1) 934 4099  
E-mail: paul.ruppert@meteolabor.ch

## APPENDIX B, p. 2

### Observers/advisors from the host country

**Dr Alaor Dall'Antonia**

Instituto Nacional de Meteorologia (INMET)  
Eixo Monumental - Via S1  
70610-400 BRASILIA DF  
Brazil  
Tel: (+55 61) 344 9955  
Fax: (+55 61)  
E-mail: alaor@inmet.gov.br

**Mr Francisco Manhães**

Instituto Nacional de Meteorologia (INMET)  
Eixo Monumental - Via S1  
70610-400 BRASILIA DF  
Brazil  
Tel: (+55 61) 343 2192  
Fax: (+55 61) .....  
E-mail: manhaes@inmet.gov.br

**Dr Gilberto Fisch**

Centro Tecnico Aeroespacial  
Instituto de Aeronáutica e Espaco (CTA-IAE-ACA)  
Pc. Mal. Eduardpo Gomes, 50  
12228-904 SJCampos-SP  
Brazil  
Tel: (+55 12) 347 4565 (or 4550)  
Fax: (+55 12) 341 2522  
E-mail: gfisch@iae.cta.br

**Mr J. Caminha Campos**

LEX International  
Tel: (+55 21) 553 7686  
Fax: (+55 21) 553 3099  
E-mail: j.caminha@vol.com.br

**CC Luis Augusto de Oliveira**

Centro Hydrografia DA  
Marinha  
Brazil  
Tel: (+55 21) 613 8260  
Fax: (+55 21) 613 8226  
E-mail: 142@chm.mar.mil.br

**Cel.-Av. José Lobato Campos**

Centro de Lancamento de Alcântara-CLA-FAB  
Av. Dos Libaneses, 29  
Aeroporto Tirirical  
São Paulo –MCEP  
Brazil  
Tel: (+55 98) 216-9202, -9203,-9000  
Fax: (+55 98) 216-9292  
E-mail: labatojc@uol.com.br

**Mr Jorge Emilio Rodrigues**

Instituto Nacional de Meteorologia (INMET)  
Eixo Monumental - Via S1  
70610-400 BRASILIA DFI  
Brazil  
Tel: (+55 61) 342 1556  
Fax: (+55 61)  
E-mail: jemilio@inmet.gov.br

**Ten Cel. Luiz Carlos Zanutto**

CINDACTA 1  
SHIS QIS Área Especial 12  
Lago Sud  
Brasila DF  
Brazil  
Tel: (+55 61) 365 1066  
Fax: (+55 61) 365 2730  
E-mail: zanutto@linkexpress.com

**Dr Luiz Augusto Toledo Machado**

Centro Tecnico Aeroespacial  
Instituto de Aeronáutica e Espaco (CTA-IAE-ACA)  
Pc. Mal. Eduardpo Gomes, 50  
12228-904 SJCampos-SP  
Brazil  
Tel: (+55 12) 347 4558  
Fax: (+55 12) 347 4551  
E-mail: machado@iae.cta.br

**Ten Cel. Carlos Edison Gomes**

DEPV – Directoria de Eletrônica e Proteáo  
AO Jôds  
Tel: (+55 21) 220 9728  
Fax: (+55 21)  
E-mail: dmet@uol.com.br

**Eng. Gilson Lima Feitosa**

Hobeco Sudamericana Ltda.  
Ladeira Madre de Deus, 13 – Gamboa  
CEP: 20221-090 – Rio de Janeiro – RJ  
Brazil  
Tel: (+55 21) 518 2237  
Fax: (+55 21) 263 9067  
E-mail: info@hobeco.net

**Mj. Carlos A.T. Moura**

Centro de Lancamento de Alcântara-CLA-FAB  
Av. Dos Libaneses, 29  
Aeroporto Tirirical  
São Paulo –MA  
Brazil  
Tel: (+55 98) 216 9309  
Fax: (+55 98) 216 9393  
E-mail: moura@iae.cta.br

### WMO Secretariat

**Mr Klaus Schulze**

World Meteorological Organization  
7 bis, Avenue de la Paix  
P.O. Box 2300  
CH-1211 Geneva 2  
Switzerland  
Tel: (+41 22) 7308-409 (direct)  
Fax: (+41 22) 7308 021 (direct)  
E-mail: schulze@wmo.ch or Schulze\_K@gateway.wmo.ch

## APPENDIX C

### Information on the local arrangements and facilities at the comparison site Alcantara

The WMO Intercomparison of GPS Radiosondes will be carried out at the Brazilian Air Force Satellite/Rocket Launch Centre (CLA), at Alcantara, situated at the State of São Luís do Maranhão, Brazil. INMET, Airforce Technological Centre (CTA), and CLA have provided information on the comparison site and the available facilities, which can be summarized as follows:

#### 1. Location:

Alcantara is located at the latitude of  $2^{\circ}18'$  South and longitude of  $44^{\circ}22'$  West. The total area of the centre is about  $620 \text{ km}^2$  though just a portion of this is used for the activities of the CLA. The Figure below shows the location of the CLA and its orientation related to the Atlantic Ocean and to São Luís City.

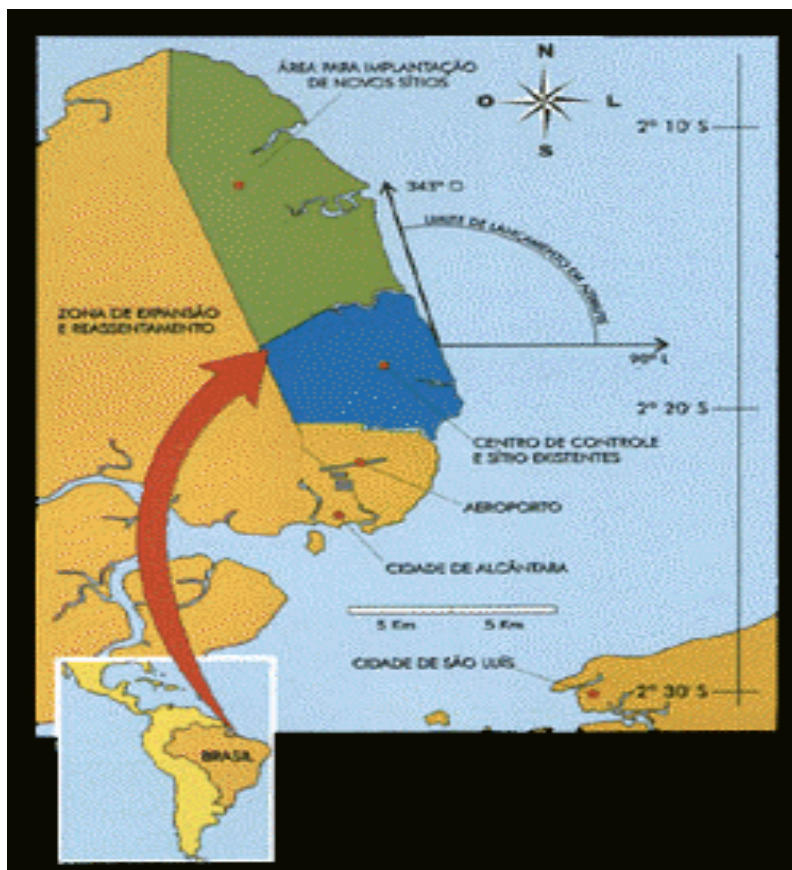

#### 2. Meteorological conditions:

Considering that the WMO Intercomparison of GPS Radiosondes will take place in May and June 2001, information about the meteorological conditions of Alcantara was provided by INMET and CTA and is contained in [Appendix E](#).

#### 3. Facilities of CLA:

The Director and the Operation Manager of CLA provided information regarding accommodation, medical assistance, travel arrangements, electrical conditions etc. at the IOC meeting, which can be summarized as follows:

##### 3.1 Transportation to the Centre:

São Luís is the Capital of the Maranhão State and has a modern International Airport link with most of the Brazil main cities as well as with some neighbour countries. It is suggested that the participants arrive at São Luís via Rio de Janeiro, São Paulo, Recife, or Manaus. The transportation to Alcantara can be done via air, using the Air Force aircraft, or crossing the Bay by using a ferry boat, or via land. Whereas the flight to Alcantara takes about 5 minutes, crossing the Bay may take 2 hours. Travelling on land may take 4 hours, due to unfavourable road conditions.

## APPENDIX C, p. 2

### 3.2 *Car rentals:*

It is suggested that participants rent a car at São Luís to facilitate the displacement at the test site. This can be arranged with the staff at Alcantara in due time.

### 3.3 *Accommodation:*

It is suggested that all participants stay at the site during the experiment. Thus, the CLA has a hotel with 20 rooms (with 1 or 2 beds), all with bathroom. All rooms are semi-furnished with TV and air-conditioning. No meals can be served at the hotel. Another option for accommodation is the use of furnished houses with 3 or 4 rooms. They have air conditioning, TV, toilets, and kitchen furniture (incl. fridge, oven, etc.).

### 3.4 *Food:*

At the main CLA restaurant breakfast and lunch will be provided or food has to be bought at local shopping to prepare the meals at the accommodation chosen. For dinner, there are other options at the Village.

### 3.5 *Medical Care:*

The CLA has a small First Aid Health Centre with 6 doctors, mostly for basic assistance and emergencies. Serious problems are necessary to be dealt with at the São Luís Hospital. There is also a local health insurance plan, which is usually offered to those, which are involved at the experiments at the CLA. The cost is very reasonable and includes the main medical assistance.

### 3.6 *Time synchronization of the participating systems:*

This matter was addressed for the participants, as there is a need to establish a coordinated time for the balloon release. The CLA operations manager informed that the Centre has already a system for synchronize procedures as well as radar tracking, which is used as normal procedure during the rocket/satellite missions. However, adaptation of this system to the RSO experiment needs may be necessary. (see proposal as reflected in [Appendix F](#).)

### 3.7 *Power supply:*

There are two options of power supply at the CLA, namely:

- The system operated by the normal local electricity company, which, however, does not provide a very stable voltage
- The Air Force power supply with a generator operated at the CLA, which provides more stable voltage than the first one.

Both systems are providing 220 and 110V / 60 Hz. The connections use the Brazilian system, where some plugs / sockets do have ground connectors while others do not have it. Participants were asked to precisely provide their needs in this regard.

### 3.8 *Permission for entering the test area:*

It was informed by the Director of the CLA that there are no restrictions for experts' participation to any country/nationality provided the required personal information of participants is available in time.

### 3.9 *Tracking Radar:*

The CLA operates an active radar system, using a magnetron and 2 passive telemetric systems. It can be applied to track the balloon during flights. There might be a limitation in using the radar due to the possibly needed new magnetron. The PL in consultation with the chairman of the IOC will address this issue in due course.

### 3.10 *Telephone facilities:*

There is one telephone company acting at the CLA, which provide external connection. This includes telephone, fax, as well as E-mail by Modem. Participants can use it.

\*\*\*\*\*

## APPENDIX D

# INFORMATION ON THE PERFORMANCE CHARACTERISTICS OF NEWLY DEVELOPED RADIOSONDES / SYSTEMS

Dr. Graw Messgeräte GmbH & Co.  
Germany

Upper Air Sounding System DFM with the following specifications<sup>7</sup>

### 1. Groundstation GK-90 C / RDGPS

- with C/A-code based windfinding
- with on-line reception and evaluation software "UNIMET" in WINDOWS NT
- data output and transfer as agreed

### 2. Radiosonde DFM-97 PTU / RDGPS

#### 2.1 Sensors

**Temperature:** high-reflecting aluminium covered bulb thermistor  
Error: <0,2°C  
Resolution: 0,1°C  
Range: -80°C to +40°C

**Humidity:** Capacitive chip-sensor  
Error: < 5 %  
Resolution: 1 %.

**Pressure:** Capacitive pressure capsule  
Error: <1.0 hPa (range 1080 hPa to 200 hPa)  
<0,5 hPa (range 200 hPa to 5 hPa)  
Resolution: 0,1 hPa

**Wind:** C/A-code based windfinding

#### 2.2 Transmitter

Frequency: 402 to 406 MHz freely programmable in 20 kHz steps  
Deviation: <5 kHz  
Transmission range: >250 km

#### 2.3 Weight of the radiosonde (ready for take off): 250g

\*\*\*\*\*

---

<sup>7</sup> The system is operational applied, radiosondes since more than two years in mass production.

**GEOLINK**

France

**SUMMARY OF TECHNICAL SPECIFICATIONS****GPSonde GL98 RADIOSONDE:****GENERAL**

Dimensions: 113 x 155 x 146 mm  
 Weight: 405 g (including batteries)

**BATTERIES**

Technology: 1.5V Alkaline  
 Autonomy: >3 h  
 Package: 8-battery pack

**SENSORS****Temperature**

Sensor type: Thermistor  
 Measurement range: +50 to -90°C  
 Resolution: 0.1°C  
 Absolute accuracy: ±0.5°C  
 Response time: <2s  
 Measurement rate: 1 Hz  
 Calibration adjustment: Calibration prior launch  
 Factory calibration: Stored in EPROM

**Humidity**

Sensor type: Capacitor  
 Measurement range: 0% to 100%  
 Resolution: 0.1%  
 Absolute accuracy: ±5%  
 Response time: <2s  
 Measurement rate: 1 Hz  
 Calibration adjustment: Calibration prior launch  
 Factory calibration: Stored in EPROM

**WIND MEASUREMENT**

General: DGPS with C/A code altitude  
 Altitude Range: Unlimited with authorisation  
 Position accuracy: 10 m  
 Horizontal Wind accuracy: 0.15 m/s  
 Wind direction accuracy: 2°  
 Position resolution: 0.01 m  
 Horizontal wind resolution: 0.01 m/s  
 Wind direction resolution: 0.1°C  
 Measurement rate: 1 Hz

**TRANSMITTER**

Frequency range: 400 to 406 MHz  
 Frequency step: 200 kHz  
 Frequency setting: Programming interface  
 Maximum drift: ±1k Hz  
 Output Power: 300 mW  
 Modulation type: Digital PSK 4800 baud

**CALIBRATION**

Measurement chain: Performed at factory and stored in EPROM. Calibration is sent with each frame of data.  
 Sensors: Calibration adjustment possible prior launch

**SR2K GROUND STATION:****GENERAL**

Dimensions: 19" rack - Width: 450 mm – Depth: 320 mm – Height: 135 mm  
 Weight: 12 kg  
 Consumption: 150 W  
 Output: Real time data, COM1, COM2, LP1, VGA, USB, PS2, Ethernet  
 Programming interface: Front panel connector with cable  
 GPS: 12-channel receiver  
 Computer functions: Non dedicated PC allowing work on others Windows applications  
 Accessories: All standard computer accessories can be connected: Printer, Modem, ...

**TELEMETRY**

Built-in receiver: 400 – 406 MHz digital Synthesiser  
 Tracking range: 250 km  
 Modulation: PSK

\*\*\*\*\*

**Vaisala Oyj**  
Finland

**A. SPECIFICATIONS OF THE RS90 RADIOSONDE****1. Meteorological sensors****1.1 Temperature:**

F-THERMOCAP® capacitance wire	
Measuring range	+60°C to -90°C
Response time (63.2 %, 6m/s flow)	
1000 hPa	0.2 s
10 hPa	0.5 s
Resolution	0.1°C
Accuracy:	
Repeatability *)	0.1°C
Uncertainty in sounding **)	0.5°C
Reproducibility in sounding ***)	
1080 - 100 hPa	0.2°C
100 - 20 hPa	0.2°C

**1.2 Humidity:** H-HUMICAP® thin film capacitor, heated twin-sensor design

Measuring range	0 to 100 % RH
Resolution:	1 % RH
Response time	
6 m/s, 1000 hPa, +20 °C	< 0.5 s
6 m/s, 1000 hPa, -40 °C	< 20 s

**cont. Humidity**

Accuracy:	
Repeatability *)	2 % RH
Uncertainty in sounding **)	5 % RH
Reproducibility in sounding ***)	2 % RH

**1.3 Pressure:** BAROCAP ® silicon sensor

Measuring range	1080 hPa to 3 hPa
Resolution	0.1 hPa
Accuracy:	
Repeatability *)	
1080 - 100 hPa	0.4 hPa
100 - 3 hPa	0.4 hPa
Uncertainty in sounding **)	
1080 - 100 hPa	1.5 hPa
100 - 3 hPa	0.7 hPa
Reproducibility in sounding ***)	
1080 - 100 hPa	0.5 hPa
00 - 3 hPa	0.3 hPa

**2 Dimensions and weight**

Radiosonde body dimensions:	150 x 90 x 50 mm <sup>3</sup>
Weight, battery activated, including unwinder:	ca 290g

**3 Battery**

Water activated battery:	19V, nominal
Operation time:	135 min

**4 Telemetry**

Transmitter type:	LC-tuned
Frequency range:	403 MHz
Tuning range:	400 - 406 MHz
Frequency stability, in 90 % probability:	<+120 kHz
Deviation, peak-to-peak:	
PTU signal nominal:	40 ±10 kHz
GPS FSK signal nominal	16 ±5 kHz
Emission bandwidth:	-40 dBc, typical 200 kHz
Output power (VBatt=15V):	200 mW minimum
Modulation:	FM
CCIR emission type:	F9D

**5 Codeless GPS receiver**

Number of channels:	8
GPS data downlink:	1200 baud, digital
Modulation:	FSK, 3200/4200 Hz
Temporal resolution:	0.5 s

**B. Fixed station (SA off, PDOP <4)\*\*\*\*):**

Wind measurement accuracy:	0.2 m/s RMS
----------------------------	-------------

**C. Mobile sounding station, without RTCM differential correction (SA off, PDOP < 4):**

Wind measurement accuracy:	0.5 m/s RMS
----------------------------	-------------

\*) standard deviation of differences between two successive repeated calibrations, k = 2 confidence level

\*\*) 2-sigma (95,5 %) confidence level (k=2), cumulative uncertainty including:

- repeatability
- long-term stability
  - effects due to measuring conditions
  - dynamic effect (such as response time)
  - effects due to measurement electronics

\*\*\*) standard deviation of differences, in twin soundings divided by  $\sqrt{2}$ .

\*\*\*\*\*) Selective Availability (SA) was switched off 1 May 2000. Position Dilution of Precision (PDOP) describes the effect of current GPS satellite geometry in radiosonde wind finding accuracy.

## INTERMET USA

### TECHNICAL SPECIFICATIONS OF THE SOUNDING SYSTEM

#### IMS Radiosonde:

##### GENERAL

Weight: 400g  
 Sampling rate: 1 Hz  
 Data channels: 8  
 Calibration: continuous  
 Range:  $\geq 250$  km

##### BATTERIES

Technology: 1.5V Alkaline (8x)  
 Operating time: 2h

##### SENSORS

##### Temperature

Sensor type: Bead thermistor  
 Measurement range:  $-95^{\circ}$  to  $+50^{\circ}\text{C}$   
 Resolution:  $0.01^{\circ}\text{C}$   
 Accuracy:  $\pm 0.3^{\circ}\text{C}$

##### Humidity

Sensor type: Capacitor  
 Measurement range: 0% to 100%  
 Resolution: 0.1%  
 Accuracy:  $\pm 5\%$

##### Pressure:

Sensor type: Solid state  
 Measurement range: 2 to 1070 hPa  
 Resolution: 0.01 hPa  
 Accuracy:  $\pm 0.5$  hPa

##### WIND MEASUREMENT

General: RDF or coded GPS  
 Lock-on time: 90s  
 Position accuracy: 500m  
 Position resolution: 100m  
 Wind speed accuracy: 1.0m/s  
 Wind speed resolution: 0.1m/s

##### TRANSMITTER

Nominal frequency: 1680/403 MHz  
 Tuning Range: 1660-1700 & 400-406 MHz  
 Modulation type: FM, Narrowband  
 Bandwidth: 10 kHz  
 Stability: Crystal controlled  
 Signal stability: 10 kHz  
 Maximum drift:  $\pm 1$  KHz  
 Sensitivity: -163 dBw  
 Transmission: 2,400 Baud, FM  
 Output Power: 300 mW  
 Polarization: Circular

#### IMS-1500 GROUND STATION:

##### System overview

Operating principle: Automatic RDF or GPS  
 Frequency: 1660 - 1700 MHz  
 Antenna type: Parabolic dish  
 Scanning principle: Solid state, sequential scan  
 Operating system: Windows 98/2000  
 Weight: 120 kg  
 Height: 2.5m  
 Base diameter: 2.0m  
 Slant tracking range: 200 km  
 Maximum altitude: 35 km

\*\*\*\*\*

APPENDIX E

**CLIMATE DATA FOR THE INTERCOMPARISON PERIOD**

*21 May to 10 June 2001*

SAO LUIZ - AIRPORT CLIMATOLOGY								
1961-1990								
SURFACE DATA								
May					June			
Local time	Temp (°C)	UR (%)	Cloud cover (OKTAS)	WS (knots)	Temp (°C)	UR (%)	Cloud cover (OKTAS)	WS (knots)
0	25.0	94	4.1	2.3	24.7	93	2.6	2.8
1	24.8	94	4.0	2.2	24.6	94	2.6	2.7
2	24.7	95	4.0	2.1	24.4	94	2.5	2.6
3	24.5	95	3.9	2.0	24.3	95	2.6	2.5
4	24.4	96	3.8	1.9	24.2	95	2.5	2.4
5	24.3	96	3.9	1.8	24.1	95	2.6	2.4
6	24.2	96	4.6	2.1	24.0	95	3.4	2.4
7	24.7	95	4.8	2.7	24.5	94	3.5	3.2
8	26.2	89	4.9	4.4	26.2	88	3.6	5.9
9	28.0	81	5.3	6.6	28.1	78	4.1	8.0
10	29.4	75	5.4	6.9	29.5	72	4.3	8.7
11	30.3	71	5.5	7.1	30.5	67	4.6	8.6
12	30.9	68	5.8	7.2	31.1	64	5.0	8.4
13	31.1	68	6.0	7.0	31.3	64	5.2	7.8
14	30.7	70	6.0	7.2	31.1	65	5.3	7.5
15	30.0	73	6.0	7.3	30.6	67	5.3	7.5
16	29.0	76	6.0	7.1	29.8	71	5.0	7.3
17	28.1	81	5.9	6.2	28.8	75	4.9	6.8
18	27.0	85	6.0	4.8	27.4	81	4.8	5.5
19	26.2	89	5.6	4.0	26.3	86	4.3	4.2
20	25.7	91	5.3	3.4	25.7	89	3.8	3.8
21	25.4	92	4.9	3.0	25.4	90	3.4	3.5
22	25.3	93	4.5	2.9	25.1	91	3.0	3.3
23	25.1	94	4.4	2.6	24.9	92	2.8	3.1

Precipitation: **May**  
290 mm

**June**  
160 mm

APPENDIX E, p. 2

SAO LUIZ - AIRPORT CLIMATOLOGY								
1961-1990								
UPPER-AIR DATA								
May					June			
Height (m)	Temp (°C)	UR (%)	WS (m/s)	WD (DEGREE)	Temp (°C)	UR (%)	WS (m/s)	WD (DEGREE)
1000	20.7	79	8.1	96	19.6	74	7.6	103
2000	15.2	73	9.3	109	13.7	71	8.9	110
3000	10.2	66	8.5	93	8.9	56	8.3	88
4000	5.0	61	7.8	82	3.9	48	7.3	82
5000	-0.2	56	7.2	80	-1.7	43	6.9	81
6000	-5.7	50	6.7	81	-7.3	35	7.5	86
7000	-11.6	45	5.2	84	-13.1	27	6.7	87
8000	-18.0	39	4.0	91	-19.7	23	5.0	88
9000	-24.9	34	2.6	101	-26.6	20	3.6	88
10000	-32.9	29	0.8	99	-34.3	19	1.8	81
11000	-40.9	26	1.3	276	-42.5	18	0.8	282
12000	-49.3	21	4.2	263	-50.5	17	3.7	261
13000	-57.6	17	7.5	261	-58.3	13	7.5	257
14000	-65.5	14	10.7	261	-65.7	11	10.6	255
15000	-72.4	11	13.7	264	-72.0	9	11.5	264
16000	-78.0	9	11.9	260	-76.2	7	7.6	274
17000	-80.6	8	4.6	260	-77.4	7	1.2	320
18000	-77.1	8	3.4	281	-73.8	6	1.4	272
19000	-72.0	6	5.6	273	-70.7	4	1.0	291
20000	-68.3	3	1.8	274	-67.3	2	2.4	92
21000	-64.6	2	2.3	90	-64.5	1	6.1	88
22000	-61.5	2	5.8	93	-61.7	1	8.0	89
23000	-58.6	2	6.0	92	-59.0	1	8.8	92
24000	-56.2	2	7.3	94	-56.5	1	13.6	92
25000	-53.8	2	11.1	92	-53.5	1	17.0	92
26000	-51.0	3	12.9	91	-51.1	1	18.2	92
27000	-48.3	2	12.3	90	-48.7	1	16.8	90
28000	-45.5	3	11.1	85	-47.0	1	17.2	90
29000	-43.6	3	10.0	87	-44.9	2	18.0	90
30000	-41.9	2	10.9	92	-42.9	2	18.4	94

## APPENDIX F

### Start pulse system proposed for application at radiosonde intercomparisons

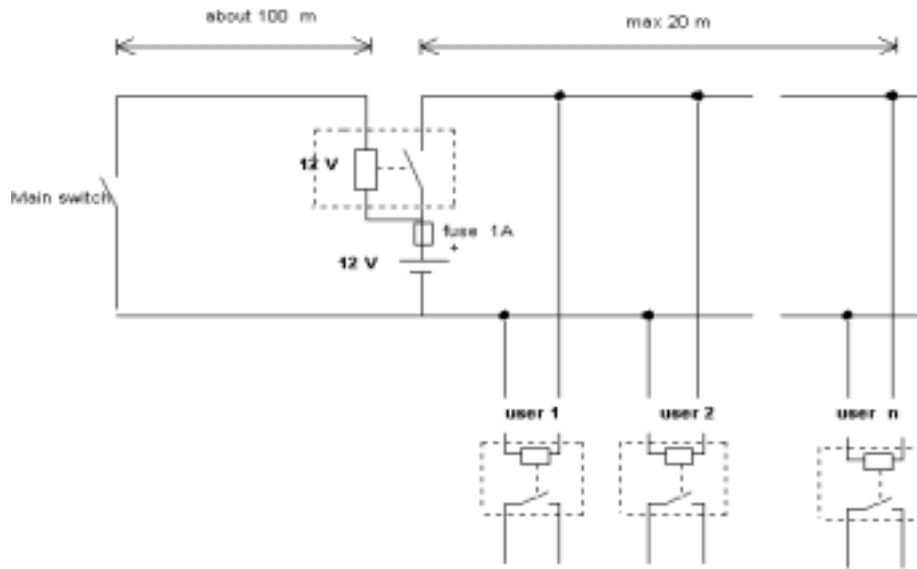

**APPENDIX G**

**Plan of main measures in preparation of the WMO Intercomparison of GPS Radiosondes**

*Alcantara, Brazil, 21 May to 10 June 2001*

#	Activity / measure	Responsibility	Month/year of implementation								Remarks
			10/00	11/00	12/00	1/01	2/01	3/01	4/01	5/01	
1	Distribution of the IOC Meeting Report	WMO Secretariat	X								
2	Invitation letter for participation to PRs	WMO Secretariat	X								
3	Development and distribution to participants of the plan for the intercomparison	PL (in consultation with Chair of IOC)	X								
4	Information of participants on local / technical details related to Alcantara	PL				X					
5	Information of participants on shipping details including address	PL		X							
6	Information of participants on experts' travel arrangements (incl. clearance form, visa, etc.)	PL					X				
7	Establishment of a <i>List of Activities</i> comprising the process of preparation	PL			X						
8	Arrival of vendors equipment in Brazil	Participants					X				It also includes METEOLABOR
9	Equipping DIGICORA with METGRAPH software	Vaisala					X				
10	Provision of an DIGICORA III system with a display which is operating with METGRAPH software	Chair of IOC						X			
11	Decision on the application of 1680 MHz for InterMet sondes	PL		X							
12	Information of the PL on the radio-frequency used	Participants		X							
13	Nomination of a Site Manager (SM) and a Data Manager (DM)	Host country		X							In coordination with the PL
14	Information of the Chair of the IOC and the participants on the names of the SM and DM	PL			X						

**APPENDIX G, p. 2**

#	Activity / measure	Responsibility	Month/year of implementation								Remarks
			10/00	11/00	12/00	1/01	2/01	3/01	4/01	5/01	
15	Provision of background information to PL	Chairman of IOC			X						
16	Procurement of balloons according given specifications (20x2000 g & 30x1200 g)	Sippican	X <sup>8</sup>				X				Funding to be shared between all participating vendors
17	Tracking radar: Consideration of the need for provision of Magnetron	PL (consultation with Chair of IOC)			X						If applicable: Information on price and proposal for funding.
18	Submission of a proposal for construction of a rack for fixing the sondes to the PL	Chair of IOC together with F. Schmidlin				X					
19	Carrying out supplementary tests of the combination "Sippican MARK II sonde with the "Snow White" dew point sensor attached	Chair of the IOC (to be done by The Met Office (UK))				X					
20	Decision on financing and availability of "Snow White" humidity sensors (preferably 20 sensors)	Chair of IOC (UK) METEOLABOR		X			X <sup>9</sup>				Funding to be shared between UK and METEOLABOR
21	Provision of "Thygan" for the test period	METEOLABOR					X				Funding by METEOLABOR
22	Decision on a test facility/chamber for sondes with "Thygan"	PL					X				
23	Decision on and provision of parachutes	NWS USA			X		X				Funding by NWS USA
24	Decision on the application of unwinders (dereelers) and on how to make them available	PL (in consultation with participants)			X						
25	Provision of radar targets	PL (INMET)					X				
26	Decision on surface sensors	PL		X							
27	Decision on launch timing pulse system	PL									
28	Decision on provision of a ceilometer for the test	Vaisala		X			(x) <sup>10</sup>				Funding by Vaisala if applicable
29	Study the air-traffic regulations applicable for ascents and apply them accordingly	PL					X				

<sup>8</sup> For clarification of types of balloons, ordering, and coordination of payment with the other participating vendors.

<sup>9</sup> Shipment to Brazil

<sup>10</sup> Shipment to Brazil, if appropriate.

**APPENDIX G, p. 3**

#	Activity / measure	Responsibility	Month/year of implementation								Remarks
			10/00	11/00	12/00	1/01	2/01	3/01	4/01	5/01	
30	Clarification whether the WMO station number of Alcantara can be used for transmission of intercomparison data at the test period	PL					X				
31	Provision of the Kurnosenko/Oakley evaluation software package to the PL and the DM	Chair of the IOC			X						
32	Illumination of the launch area & balloon at night	PL						X			
33	Submission of personal information for getting permission for access to the test area Alcantara	Participants						X			
34	Information of the PL on power supply requirements	Participants					X				
35	Development of a plan for data acquisition and processing	PL in collaboration with PM						X			
36	Development of the project structure and the detailed comparison schedule by the PL and submission to the chair of the IOC for approval	PL					X				
37	Determination of the GPS Position for the participating ground stations	PL						X			
38	Arrival of participants at Alcantara	Participants								X	

APPENDIX H

Flow chart for data provision and processing

